



## DESIGN OF AN ALERT SYSTEM FOR GAS LEAKAGE

**ILONWAFOR CHUKWUKA LEVI**

*School of Engineering, Department of Electrical/ Electronics,  
Federal Polytechnic Oko.*

### **Abstract**

*Liquefied Petroleum Gas (LPG) is a main source of fuel, especially in urban areas because it is clean compared to firewood and charcoal. Gas leakage is a major problem in the industrial sector, residential premises, etc. Nowadays, home security has become a major issue because of increasing gas leakage. Gas leakage is a source of great anxiety with ateliers, residential areas and vehicles like Compressed Natural Gas (CNG), buses, and cars which are run on gaspower. One of the preventive methods to stop accidents associated with the gas leakage is to install a gas leakage detection kit at vulnerable places. The aim of this paper is to propose and discuss a design of a gas leakage detection system that can automatically detect, alert and control gas leakage. This proposed system also includes an alerting system for the users. The system is based on a sensor that easily detects a gas leakage.*

**Keywords:** *LPG (liquefied petroleum gas); gas sensor MQ-6; buzzer (alarm); LED (light).*

### **Introduction**

Gas leakage is a serious problem and nowadays it is observed in many places like residences, industries, and vehicles like Compressed Natural Gas (CNG), buses, cars, etc. It is noticed that due to gas leakage, dangerous accidents occur. The Liquefied petroleum gas (LPG), or propane, is a flammable mixture of hydrocarbon gases used as fuel in many applications like homes, hostels, industries, automobiles, and vehicles because of its desirable properties which include high calorific value, less smoke, less soot, and meager harm to the environment. Liquid petroleum gas (LPG) is highly inflammable and can burn even at some distance from the source of leakage. This energy source is primarily composed of propane and butane which are highly flammable chemical compounds. These gases can catch fire easily. In homes, LPG is used

mainly for cooking purposes. When a leak occurs, the leaked gases may lead to an explosion. Gas leakage leads to various accidents resulting in both material loss and human injuries. Home fires have been occurring frequently and the threat to human lives and properties has been growing in recent years. The risks of explosion, fire, suffocation are based on their physical properties such as toxicity, flammability, etc. The number of deaths due to the explosion of gas cylinders has been increasing in recent years. The Bhopal gas tragedy is an example of accidents due to gas leakage.

The reason for such explosions is due to substandard cylinders, old valves, no regular checking of gas cylinders, worn out regulators and a lack of awareness of handling gas cylinders. Therefore, the gas leakage should be detected and controlled to protect people from danger. An odorant such as ethane thiol is added to LPG, so that leaks can be detected easily by most people. However, some people who have a reduced sense of smell may not be able to rely upon this inherent safety mechanism. A gas leakage detector becomes vital and helps to protect people from the dangers of gas leakage. A number of research papers have been published on gas leakage detection techniques [1–8]. K. Padmapriya et al. proposed the design of a wireless LPG monitoring system. In this paper, the user is alerted about the gas leakage through SMS and the power supply is turned off [6]. Meenakshi Vidya et al. proposed the leakage detection and real time gas monitoring system. In this system, the gas leakage is detected and controlled by means of an exhaust fan. The level of LPG in cylinder is also continuously monitored [7]. Selvapriya et al. proposed the system in which the leakage is detected by the gas sensor and produce the results in the audio and visual forms. It provides a design approach on software as well as hardware [8]. In the existing method, different gas sensing technology is used.

In this paper a low-cost advanced sensor-based gas leakage detector, alert and control system is proposed and discussed. The system is very efficient, user friendly, portable, small in size and cost effective. It will cost only 917 Bangladeshi taka which is equivalent to ten USD.

### **Method and Materials**

In this paper, semiconductor sensors are used to detect LPG gas. An MQ6 semiconductor sensor is used. Sensitive material of the MQ-6 gas sensor is SnO<sub>2</sub>, which has lower conductivity in clean air. When the target combustible gas exists, the sensor conductivity increases along with the rising gas concentration. The MQ6 gas sensor has a high sensitivity to Propane, Butane

and LPG, and response to Natural gas. The sensor could be used to detect different combustible gasses, especially Methane; it has a low cost and is suitable for different applications. The MQ-6 can detect gas concentrations anywhere from 200 to 10,000 ppm. The sensor's output is an analog resistance. Figure 1 shows the block diagram of the gas leakage detection and alert system.

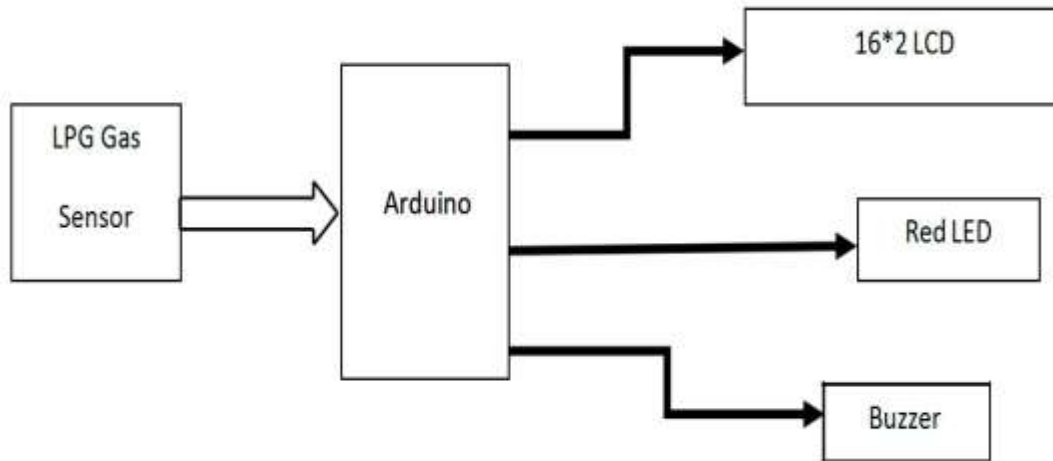

**Figure 1.** Block diagram of gas leakage detection and alert system.

This system is based on the Arduino UNO R3 and MQ-6 gas sensor. When the sensor detects gas in the atmosphere, it will give digital output 1 and if gas is not detected the sensor will give digital output 0. Arduino will receive the sensor output as digital input. If the sensor output is high, then the buzzer will start tuning along with the LCD that will show that "Gas detected: Yes". If the sensor output is low then buzzer will not be tuning, and the LCD will show that "Gas detected: No". The buzzer most commonly consists of a number of switches or sensors connected to control unit that determines which button was pushed or whether a preset time has lapsed, and usually illuminates a light on the appropriate button or control panel, and sounds a warning in the form of a continuous or intermittent buzzing or beeping sound.

For the design of a sensor-based gas leakage detector and alarm system the following hardware components are required. Table 1 lists the list of required hardware components, quantity and price in Bangladeshi Taka. The gas detector system is very cheap and it will cost only 917 BD Taka. The device is portable, light weight, user friendly and efficient with multi-functional features. In Figure 2, some important components that are needed to design the gas leakage detection and alert system are presented.

**Table 1.** List of required hardware opponents, quantity and price in Bangladeshi Taka.

Equipment	Quantity	Price (BDT)
Arduino Uno R3	1	420/-
MQ-6 LPG gas sensor	1	160/-
16*2 LCD	1	124/-
Buzzer	1	15/-
Male to male/female wire	40	60/-
9 V Battery	1	40/-
Gas Lighter	1	35/-
10 K Variable Resistor	1	8/-
Mini Breadboard	1	55/-

Total Taka-917/-



**Figure 2.** Some important components that are needed to design the gas leakage detection and alert system.

### Results and Analysis

The Proteus Design Suite is a proprietary software tool suite used primarily for electronic design automation. The software is used mainly by electronic design engineers and technicians to create schematics and electronic prints for manufacturing printed circuit boards. Figure 3 shows the circuit diagram that was designed using Proteus libraries. This system is based on Arduino UNO R3 and MQ-6 gas sensor. When the sensor detects gas in atmosphere, it will give a

digital output of 1 and if gas is not detected the sensor will give a digital output of 0. Arduino will take the sensor output as the digital input. If sensor output is high, then the buzzer will start tuning and the LCD will show that “Gas detected: Yes”. If sensor output is low then the buzzer will not be tuning, LCD will show that “Gas detected: No”. The detector incorporates a MQ-6 sensor (with gas detection range of 300–10,000 ppm) as the LPG gas sensor, PIC16F690 microcontroller as the control unit, LCD for displaying gas concentration, a buzzer as an alarm and a number of LEDs to indicate the gas leakage status.

The microcontroller senses the presence of a gas when the voltages signal from the MQ-6 sensor goes beyond a certain level and gives an audiovisual alarm.

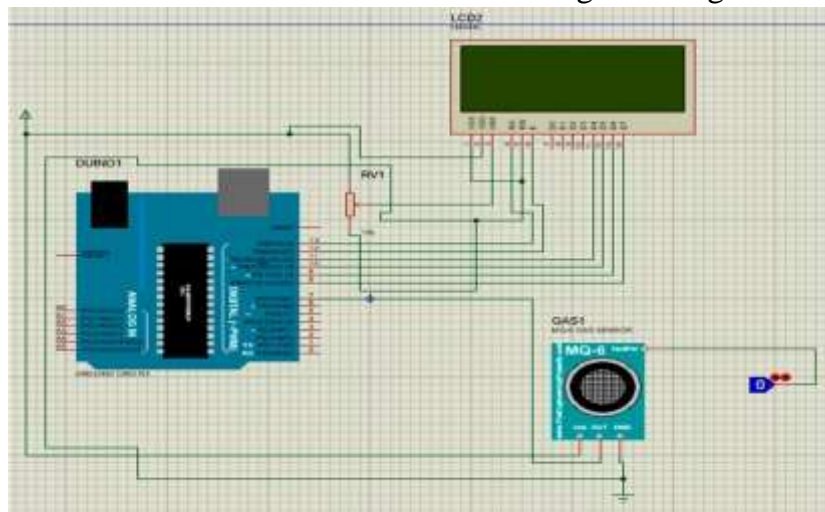

**Figure 3.** Circuit diagram that was designed using Proteus libraries.

Figure 4 shows the circuit diagram of the MQ-6 gas sensor connected with Arduino.

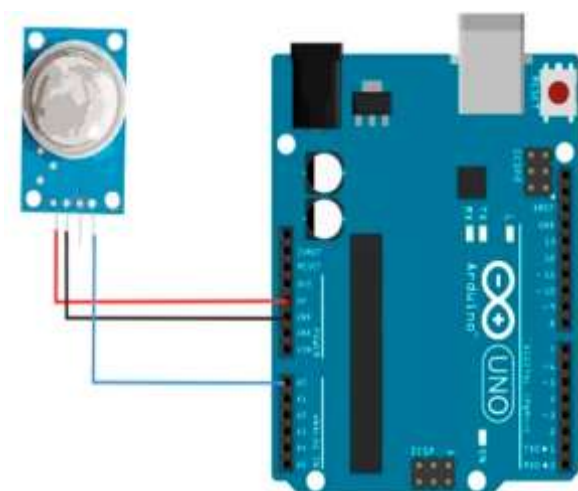

**Figure 4.** Circuit diagram of MQ-6 gas sensor connected with Arduino.

If the system detects the level of gas in the air that exceeds the safety level it will activate the alarm which includes the buzzer to alert the users at home of the abnormal condition and to take any necessary action. The most

tell-tale sign of a leak is the smell of gas in the home. However, in the case of a carbon monoxide leak, there are also particular physical symptoms you may suffer from if there is a leak. The output result of this paper is that the leakage will be detected and stopped within 2 s after the leakage starts. This system can even detect the level of gas leakage. This is an efficient method for automatically detecting and controlling the gas leakage. Moreover, the fire accidents are also prevented by switching off the power supply. The idea for gas detection and control can be implemented at a large scale for various industries. This system can be installed in a kitchen, at a hostel cafeteria, and any other areas. This can be helpful in reducing accidents caused by gas leakage in household as well as in any similar commercial set up. In our country there are 180 million people, and due to its low cost this product is affordable and will prevent many accidents and save many properties and human lives.

### **Future Work**

Overall, software and hardware parts of the systems have been developed and tested by introducing a small amount of LPG near gas sensor module. The authors of this paper are currently working to include multi functions with this device. One of the notable future functions of this system is to add a sub system where wastage of gas and the uses of gas can be monitored using this system. The system is flexible as a greater number of sensors and relays can be added to it according to the whole LPG supply setup in those premises. The author is adding more software based intelligent functions with this system. This is an automatic gas detection, control and alert system. In future this system will have a feature where it can notify the emergency services if any accidents happen. A mobile app and web-based app for real time monitoring also will be added. In the user app for this system many smart features will be added. The overall features will make the system more safe for the users. The system will be optimized for use in many places like the car, the home, industries and many other places. After designing the final prototype with smart multifunctional features, the system will be implemented in real life scenarios as a pilot project. A survey will be done soon before using the system and another one will be done after implementing the system to discover the KPI. Summarizing all the results, finding and analyzing a research article will be done and author has plans to submit it to the MDPI *sensors* journal for review. In the future paper the features of this final product will be compared with the available gas detector systems presented in other articles.

## Conclusions

The design of a sensor-based automatic gas leakage detector with an alert and control system has been proposed and discussed in this paper. This is a low-cost, low power, lightweight, portable, safe, user friendly, efficient, multi featured and simple system device for detecting gas. Gas leakage detection will not only provide us with significance in the health department but it will also lead to raise our economy, because when gas leaks it not only contaminates the atmosphere but also wastage of gases will hurt our economy. The proposed system will cost only USD 10 which is easily affordable even for poor people. In the open literatures it is noticed that much work has not been done for a smart gas detection system. In future, more advanced features will be integrated with this system which will provide users with more safety and relaxation. The proliferation of handheld devices has led to developments in the field of smart gas sensors, which has considerably widened their scope of application. The need for ensuring safety in workplaces is expected to be the key driving force for the market over the coming years.

**Funding:** This research received no external funding.

**Acknowledgments:** The authors of this paper would like to thank Electrical and Computer Engineering Department at North South University Bangladesh.

**Conflicts of Interest:** The authors declare no conflict of interest.

## References

- Mahalingam, A.; Naayagi, R.T.; Mastorakis, N.E. Design and implementation of an economic gas leakage detector. In Proceedings of 6th International Conference on Circuits, Systems and Signals, Athens, Greece, 7–9 March 2012; pp. 20–24.
- Attia, H.A.; Halah, Y.A. Electronic Design of Liquefied Petroleum Gas Leakage Monitoring, Alarm, and Protection System Based on Discrete Components. *Int. J. Appl. Eng. Res.* **2016**, *11*, 9721–9726.
- Apeh, S.T.; Eramah, K.B.; Iruansi, U. Design and Development of Kitchen Gas Leakage Detection and Automatic Gas Shut off System. *J. Emerg. Trends Eng. Appl. Sci.* **2014**, *5*, 222–228.
- Soundarya, T.; Anchitalagammai, J.V.; Priya, G.D.; Karthickkumar, S.S. C-Leakage: Cylinder LPG Gas Leakage Detection for Home Safety. *IOSR J. Electron. Commun. Eng.* **2014**, *9*, 53–58.
- Shrivastava, A.; Prabhaker, R.; Kumar, R.; Verma, R. GSM based gas leakage detection system. *Int. J. Emerg. Trends Electr. Electron.* **2013**, *3*, 42–45.
- Anurupa, A.; Gunasegaram, M.; Amsaveni, M. Efficient Gas Leakage Detection and Control System using GSM Module. *Int. J. Eng. Res. Technol.* **2015**, *3*, 1–4.

Meenakshi, A.A.; Meghana, R.B.N.; Krishna, P.R. LPG Gas Leakage Detection and Prevention System. *Int.*

*J. Future Revolut. Comput. Sci. Commun. Eng.* **2017**, 3, 1–4.

All Answers Ltd. GSM Based LPG Detection [Internet]. November 2018. Available online: <https://ukdiss.com/examples/gsm-based-lpg-detection.php?vref=1> (accessed on 15 October 2020).